

# LIO ROH

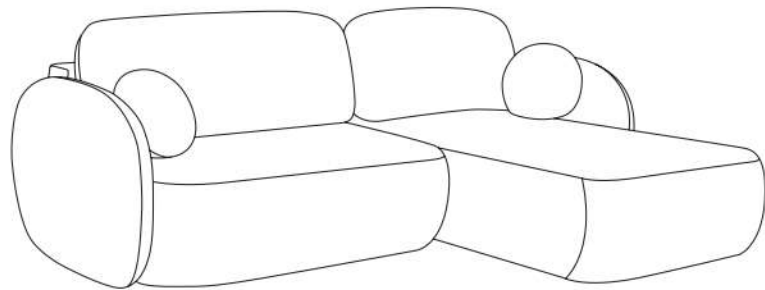

45 min.



L

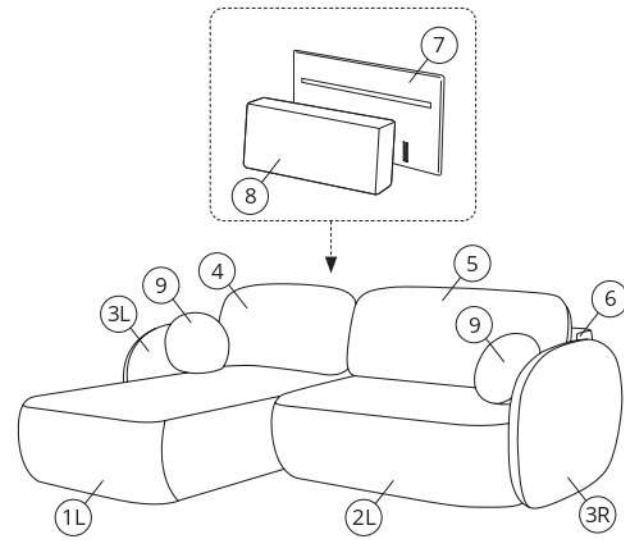

R

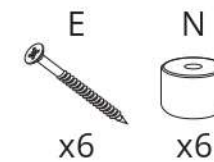
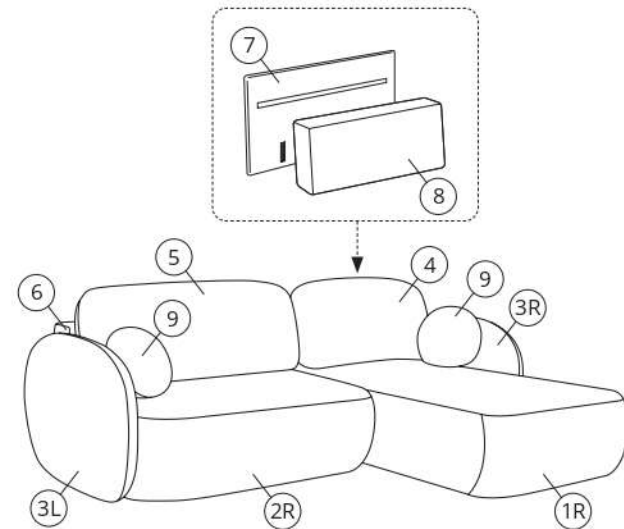



5L 

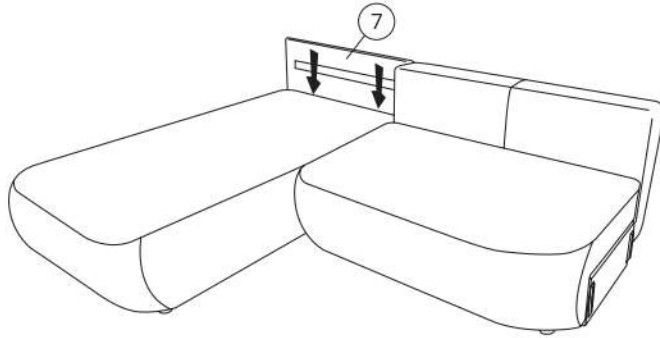
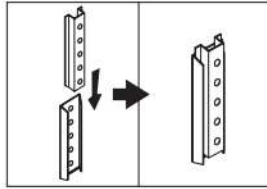

 7L

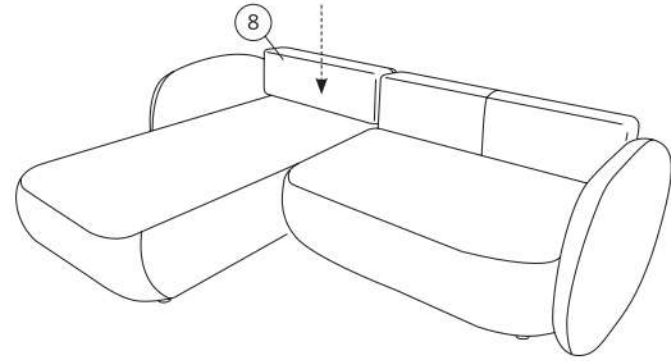

6L 

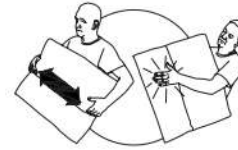
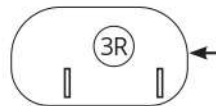
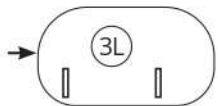
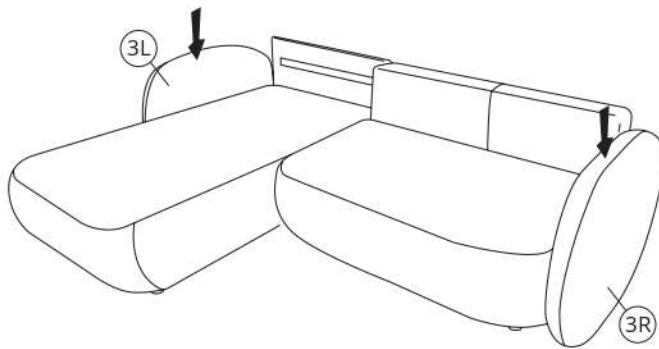
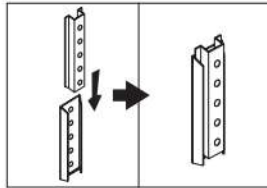

 8L

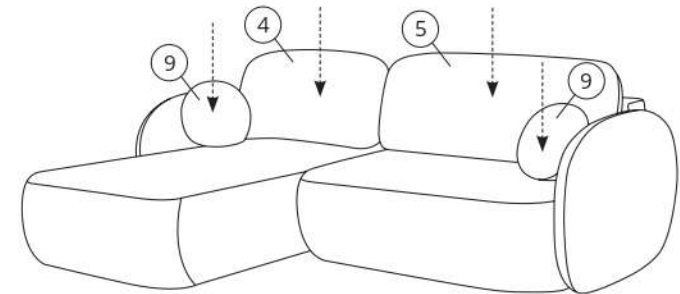

9L 

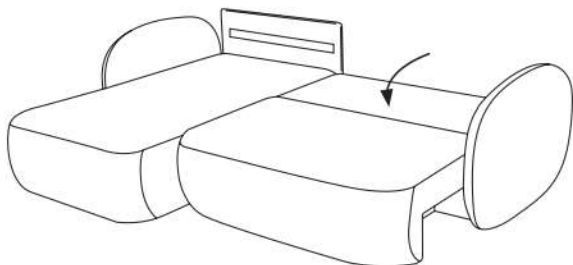
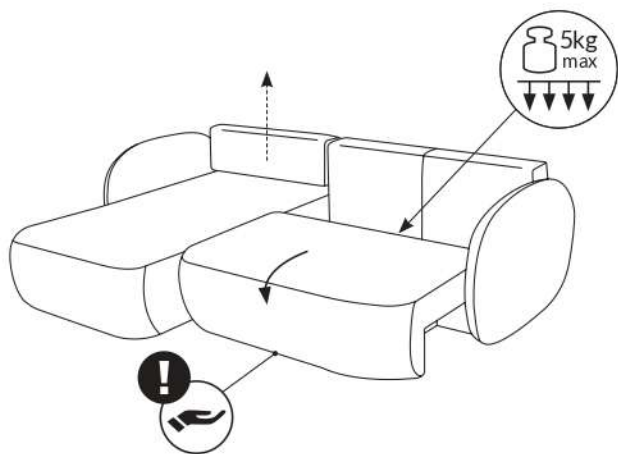
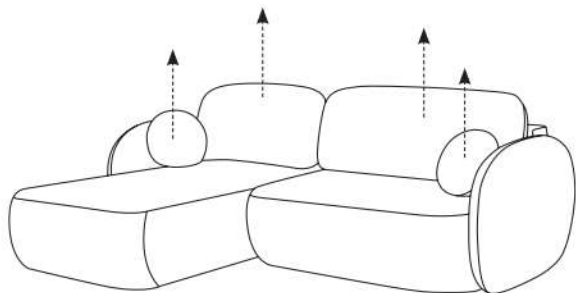

1R 

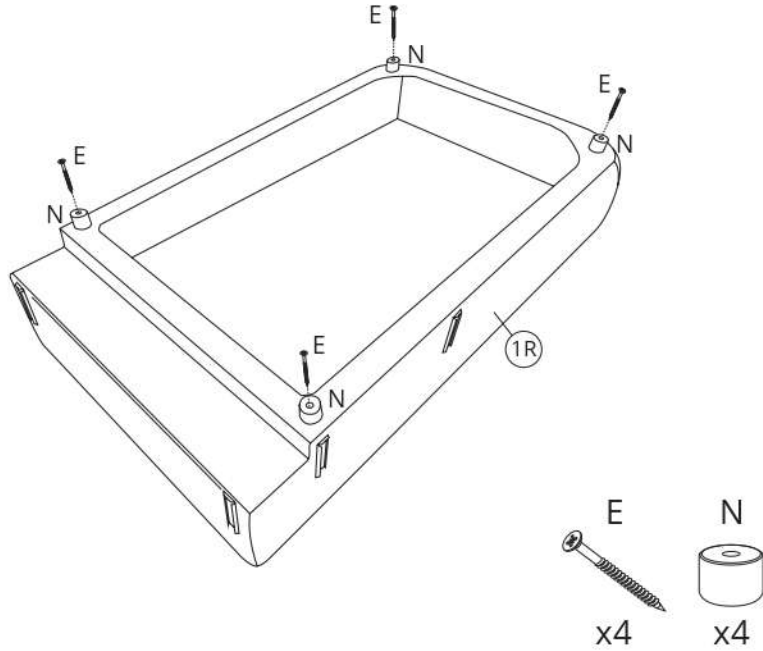

2R 

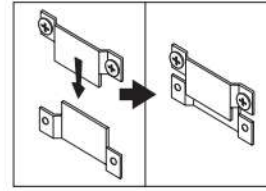
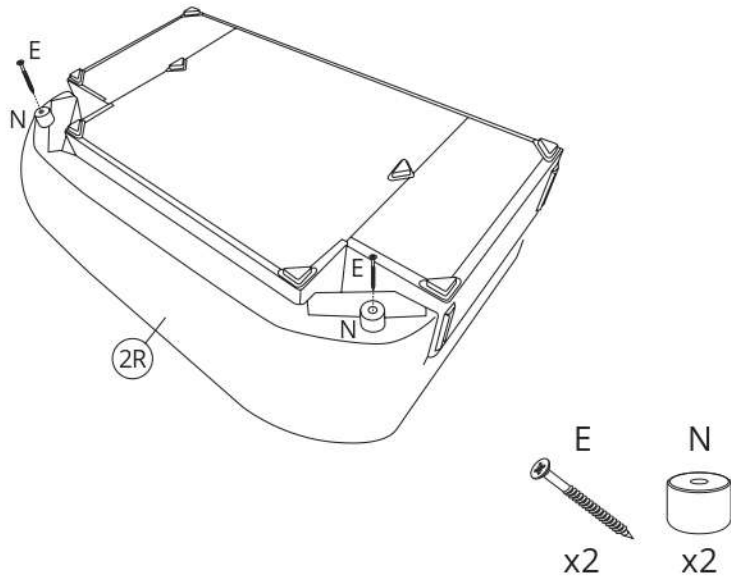

 3R

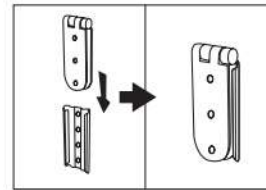
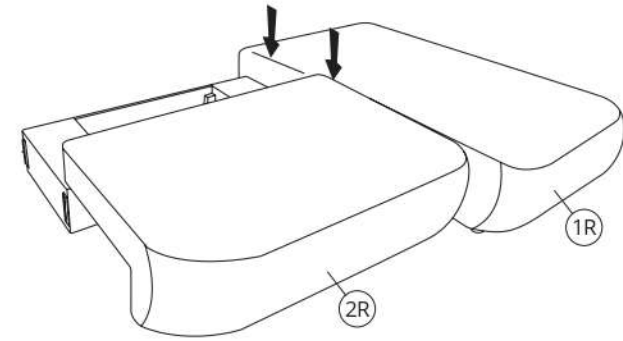

 4R

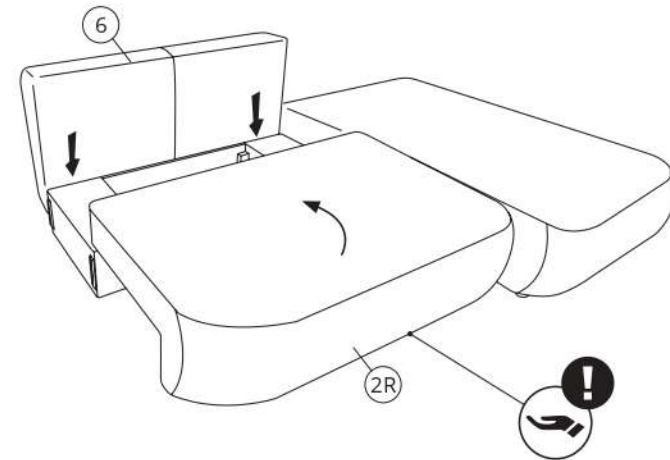

5R 

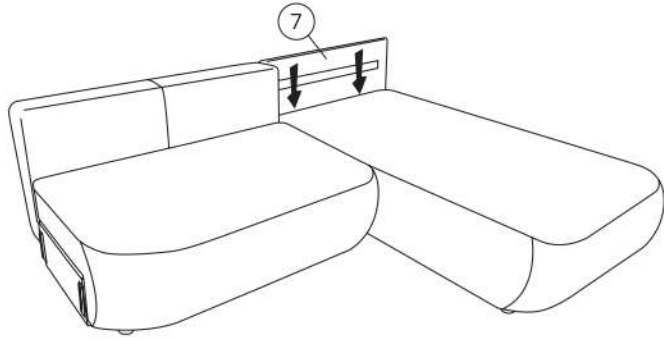
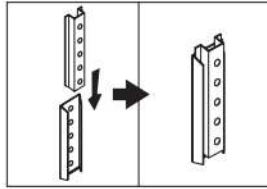

 7R

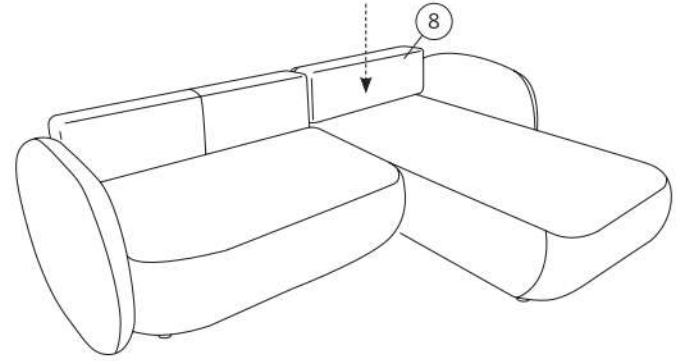

6R 

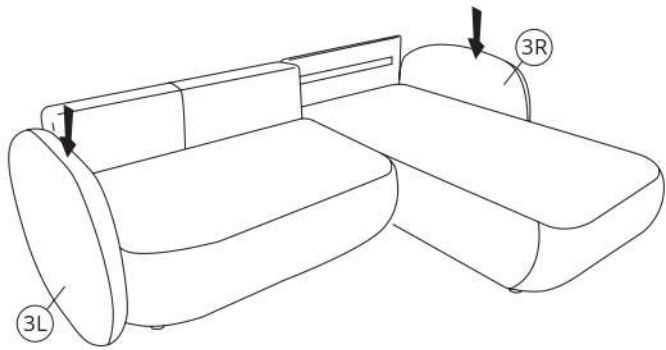
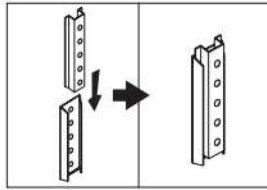

 8R

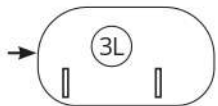
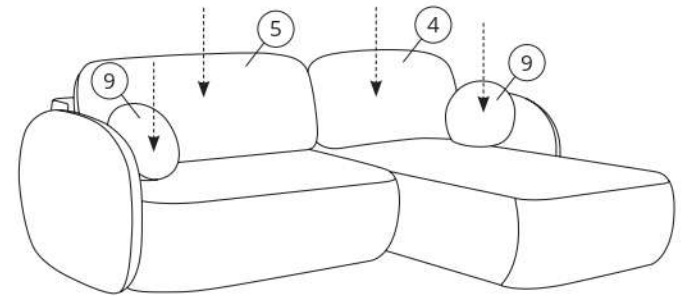

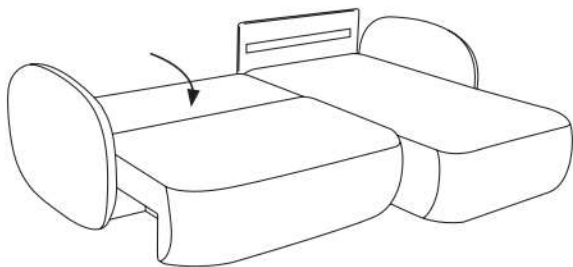
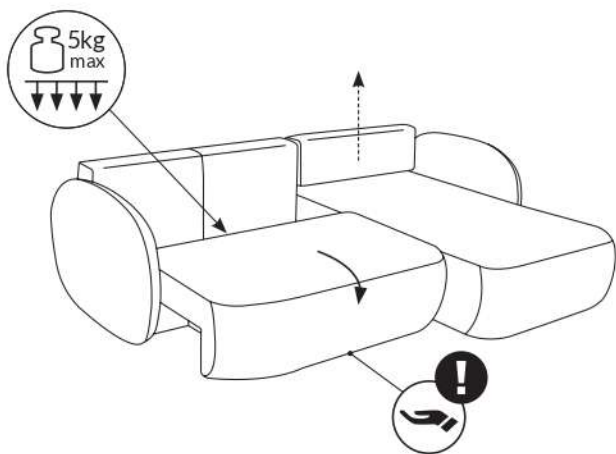
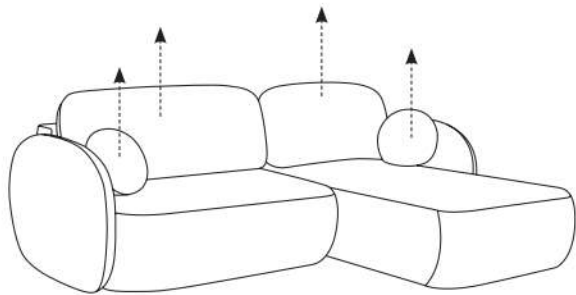

L

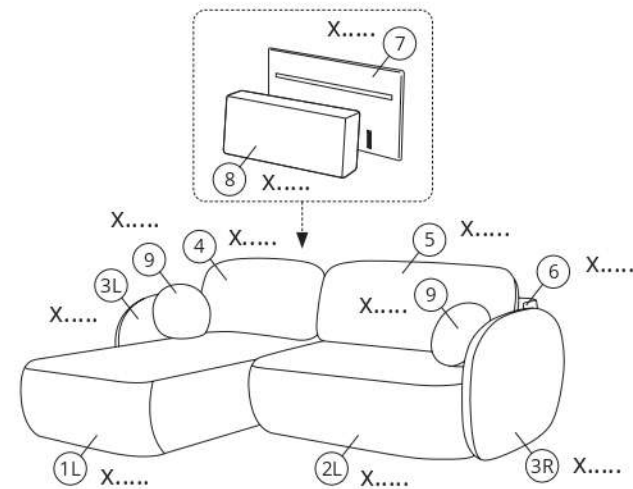

R

